

Gilkon FP7v100

Flat Screen Mobile Lift – Electric

GILKON

The new Gilkon FP 7v100 is a heavy duty mobile mount for large flat screens. Featuring robust engineering and height adjustable controls that delivers a high capacity, smooth lifting motion. Now with increased screen size options and screen mounting brackets for larger VESA patterns, the Gilkon FP 7v100 is perfectly suited for touch screens (landscape orientation).



DIMENSIONS

Height (raised)	1896mm
Height (closed)	1246mm
Depth	758mm
Width	1050mm



Wired Remote Included

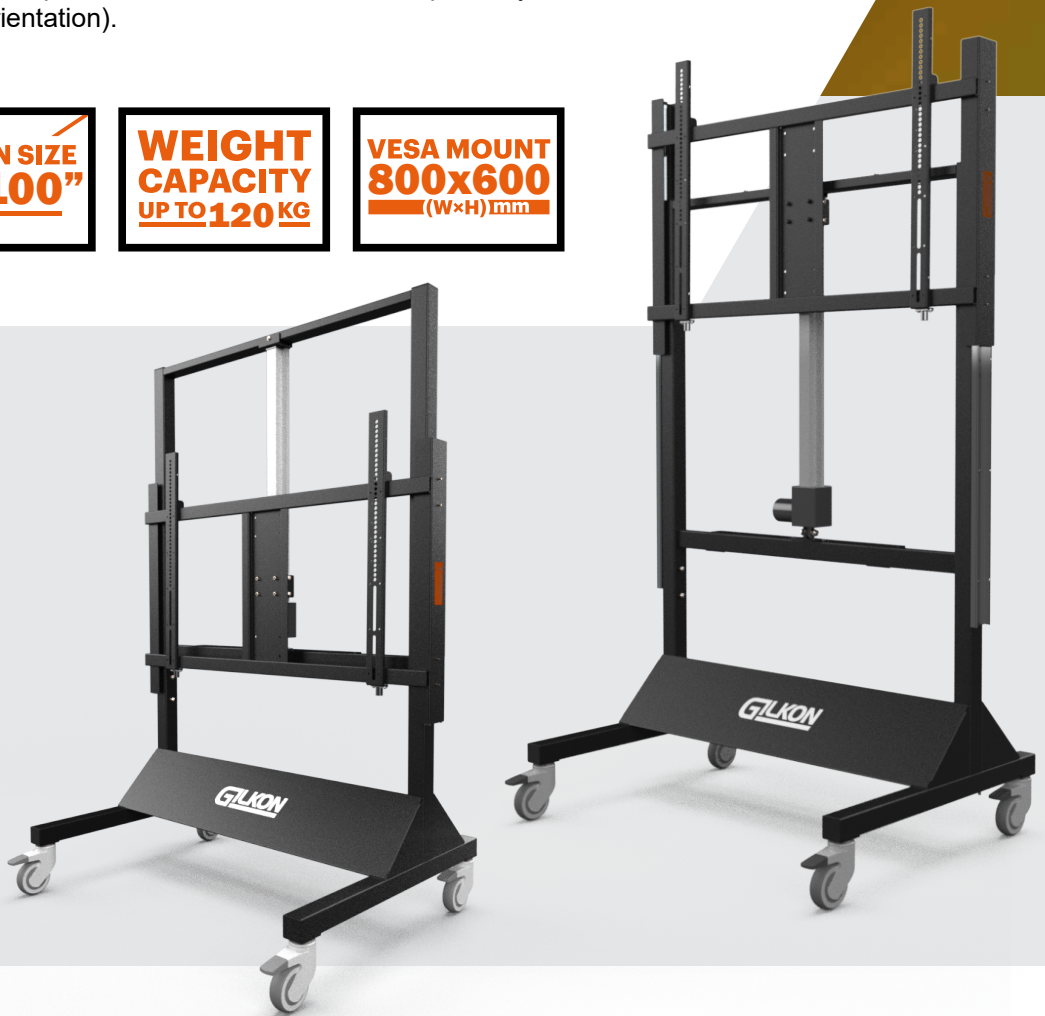

FEATURES

- Wired remote included
- Whisper quiet motor to raise and lower
- Enclosed cable management
- Height adjustable (raised height is approximately 1896mm)
- New glide action when adjusting height. Holds most screens from 42" to 100"
- Maximum weight capacity holds up to 120kgs
- Supports more VESA mounting hole patterns from 75mm to 800mm wide and from 75mm to 600mm high
- Key Lockable screen mount to deter theft
- Lockable heavy duty castors
- Robust tube steel frame
- Mount holes for optional horizontal laptop shelf
- 5 YEAR WARRANTY

STANDARD COLOUR

- Black texture finish



OPTIONAL ACCESSORIES

- Laptop shelf
- MLD Kit
 - VESA mounting plate
 - Keyboard & mouse pocket
 - Camera mount

Specifications



Part Number: 8IMFP7v100

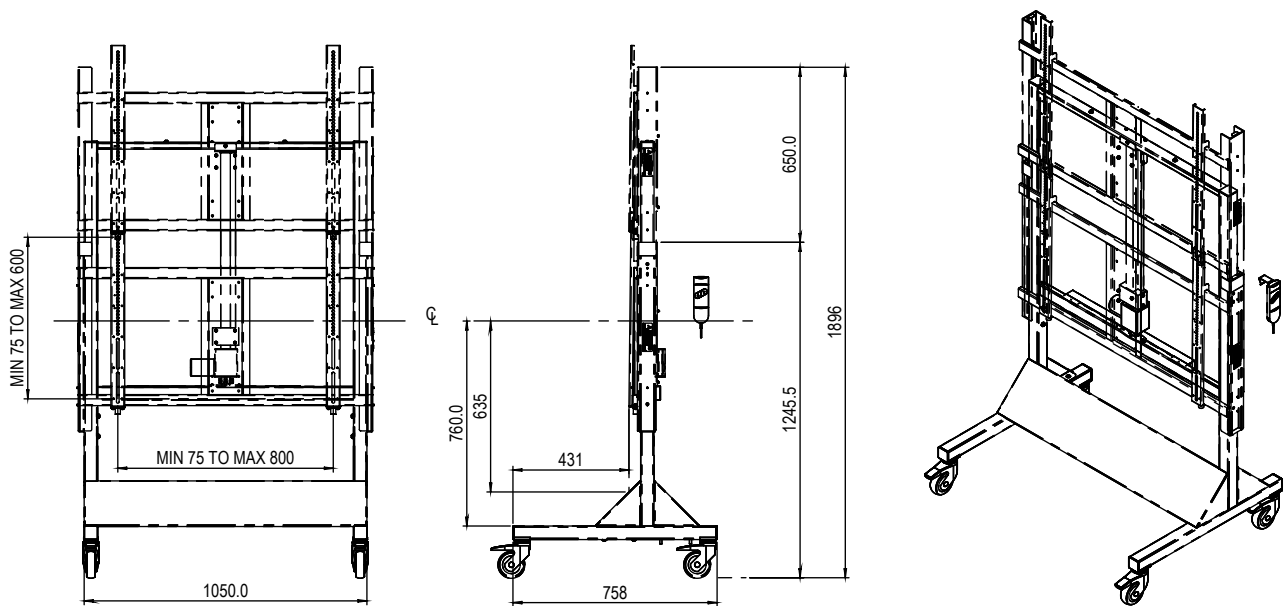

Screen mounting compatibility: supports VESA mounting hole patterns from 75mm to 800mm wide and from 75mm to 600mm high

Accessories

Laptop Shelf

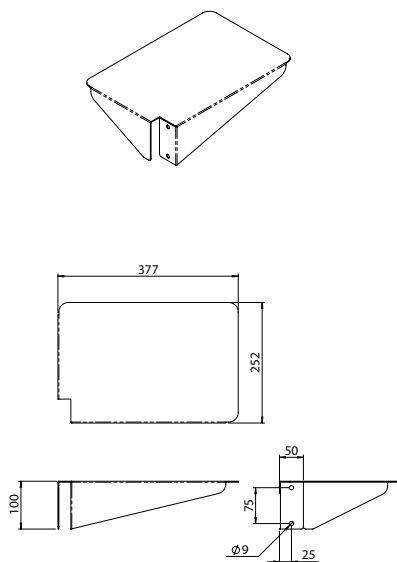

MLD Kit

- VESA mounting plate
- Keyboard & mouse pocket
- Camera mount

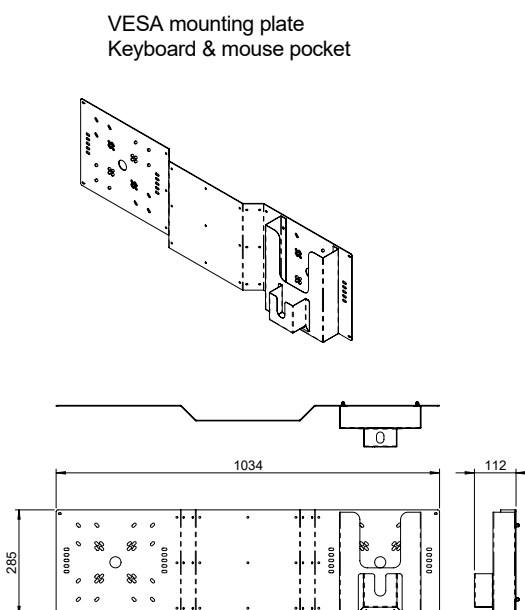

Camera mount

